

- 7** ↗ INDICATES CHASSIS GROUND
6 ∇ INDICATES FLOATING GROUND
5 ALL COILS ARE IN MICROHENRIES
4 CAPACITORS < 1 ARE IN MICROFARADS, 25V
3 CAPACITORS > 1 ARE IN PICOFARADS, 1000V
2 ALL DIODES ARE IN4151
1 ALL RESISTORS ARE 1/4W, 5%
- 8 SEMI-DUPLEX OPERATION (241-717503-701)**
 a) COMP. IN BOX "1" ARE FOR SEMI-DUPLEX
 b) IN EX. SHOWN HERE CH. 3 & 5 ARE SEMI-DUPLEX & WERE OBTAINED BY SOLDERING A JUMPER BETWEEN CH3 & CH20 SQUARE PADS & A JUMPER BETWEEN CH5 & CH19 SQUARE PADS
 YI-1 TO YI-11 ARE RECEIVE CRYSTALS
 YI-12 TO YI-20 ARE TRANSMIT CRYSTALS
- 9 A/B 20 CHANNEL OPERATION (241-737563-701)**
 a) COMPONENTS SHOWN IN DOTTED LINE PLUS ALL THE COMPONENTS NECESSARY FOR SEMI-DUPLEX ARE NEEDED FOR 20 CHANNEL OPERATION
 b) C25 IS DELETED
 c) CR4-11 TO 20 DIODES ARE DELETED ON ALL CHANNELS EXCEPT THOSE REQUIRED FOR SEMI-DUPLEX OPERATION
- 10 AUTOMATIC MODE REVERSION TO A3A OR A3H 241-717562-701**
 AUTOMATIC MODE TO A3A OR A3H IS OBTAINED BY ADDING A DIODE BETWEEN THE CHANNEL PAD AND THE A3A LINE OR A3H LINE. IN EX. SHOWN HERE CH1 IS AUTOMATIC MODE TO A3H AND CH2 TO A3A. ALL OTHER CHANNELS ARE USB OR AS DETERMINED BY THE FRONT PANEL MODE SWITCH
- 11 JUMPER W2 IS DELETED & JUMPER W3 IS ADDED ONLY WHEN A 10th SEMI-DUPLEX CHANNEL OR WHEN A 10 CHANNEL POSITION WITH A/B 20 CHANNEL KIT IS NEEDED. SIMILARLY CR4-11 DIODE IS ADDED ONLY IF A 10 SEMI-DUPLEX CHANNEL IS NEEDED. THIS IS A SILICON DIODE SUCH AS IN4151, IN4148, 1N94, ETC**
- 12 UNITS MAY NOT BE FULLY EQUIPPED FOR 11 CHANNELS, EXTRA CHANNELS ARE AVAILABLE AS "CHANNEL KIT CMC 241-717560-701"**
- 13 LSB, A/B 20 CHANNELS AND SEMI-DUPLEX ARE OPTIONAL**
- 14 LSB OPERATION (241-717504-701)**
 a) COMP. IN BOX "2" PLUS L1-1 TO L1-11 & CR2-1 TO CR2-11 ARE FOR LSB OPERATION
 b) CUT-OFF W1-1 WHEN CH1 IS LSB
 CUT-OFF W1-2 WHEN CH2 IS LSB, ETC
 c) CUT-OFF W4 FOR LSB OPERATION

FIGURE 7-2 HFO/BFO SCHEMATIC DIAGRAM

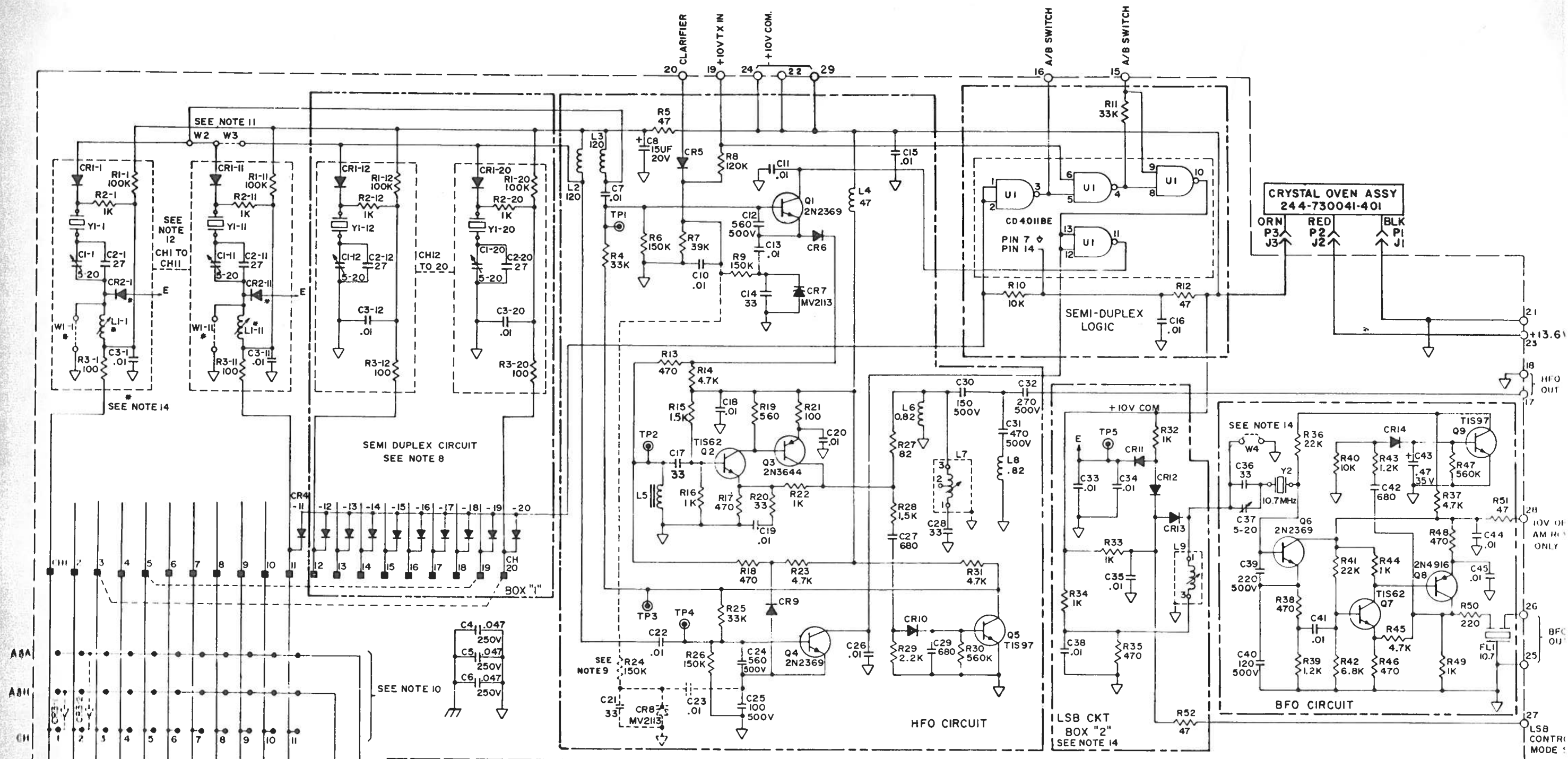

- 7 ⚡ INDICATES CHASSIS GROUND
 8 ⚡ INDICATES FLOATING GROUND
 5 ALL COILS ARE IN MICROHENRIES
 4 CAPACITORS < 1 ARE IN MICROFARADS, 25V
 3 CAPACITORS > 1 ARE IN PICOFARADS, 1000V
 2 ALL DIODES ARE IN4151
 1 ALL RESISTORS ARE 1/4W, 5%
- NOTES (UNLESS OTHERWISE SPECIFIED)
- 8 SEMI-DUPLEX OPERATION (241-717503-701)
 a) COMP. IN BOX "1" ARE FOR SEMI-DUPLEX
 b) IN EX. SHOWN HERE CH. 3 & 5 ARE SEMI-DUPLEX & WERE OBTAINED BY SOLDERING A JUMPER BETWEEN CH3 & CH20 SQUARE PADS & A JUMPER BETWEEN CH5 & CH19 SQUARE PADS
 Y1-1 TO Y1-11 ARE RECEIVE CRYSTALS
 Y1-12 TO Y1-20 ARE TRANSMIT CRYSTALS
- 9 A/B 20 CHANNEL OPERATION (241-737563-701)
 a) COMPONENTS SHOWN IN DOTTED LINE PLUS ALL THE COMPONENTS NECESSARY FOR SEMI-DUPLEX ARE NEEDED FOR 20 CHANNEL OPERATION
 b) C25 IS DELETED
 c) CR4-11 TO 20 DIODES ARE DELETED ON ALL CHANNELS EXCEPT THOSE REQUIRED FOR SEMI-DUPLEX OPERATION
- 10 AUTOMATIC MODE REVERSION TO A3A OR A3H 241-717562-701
 AUTOMATIC MODE TO A3A OR A3H IS OBTAINED BY ADDING A DIODE BETWEEN THE CHANNEL PAD AND THE A3A LINE OR A3H LINE. IN EX. SHOWN HERE CH1 IS AUTOMATIC MODE TO A3H AND CH2 TO A3A ALL OTHER CHANNELS ARE USB OR AS DETERMINED BY THE FRONT PANEL MODE SWITCH
- 11 JUMPER W2 IS DELETED & JUMPER W3 IS ADDED ONLY WHEN A 10th SEMI-DUPLEX CHANNEL OR WHEN A 10 CHANNEL POSITION WITH A/B 20 CHANNEL KIT IS NEEDED. SIMILARLY CR4-11 DIODE IS ADDED ONLY IF A 10 SEMI-DUPLEX CHANNEL IS NEEDED. THIS IS A SILICON DIODE SUCH AS IN4151, IN4148, W94 ETC
- 12 UNITS MAY NOT BE FULLY EQUIPPED FOR 11 CHANNELS, EXTRA CHANNELS ARE AVAILABLE AS "CHANNEL KIT CMC 241-717560-701"
- 13 LSB, A/B 20 CHANNELS AND SEMI-DUPLEX ARE OPTIONAL
- 14 LSB OPERATION (241-717504-701)
 a) COMP. IN BOX "2" PLUS L1-1 TO L1-11 & CR2-1 TO CR2-11 ARE FOR LSB OPERATION
 b) CUT-OFF W1-1 WHEN CH1 IS LSB
 CUT-OFF W1-2 WHEN CH2 IS LSB, ETC
 c) CUT-OFF W4 FOR LSB OPERATION

FIGURE 7-2 HFO/BFO SCHEMATIC DIAGRAM

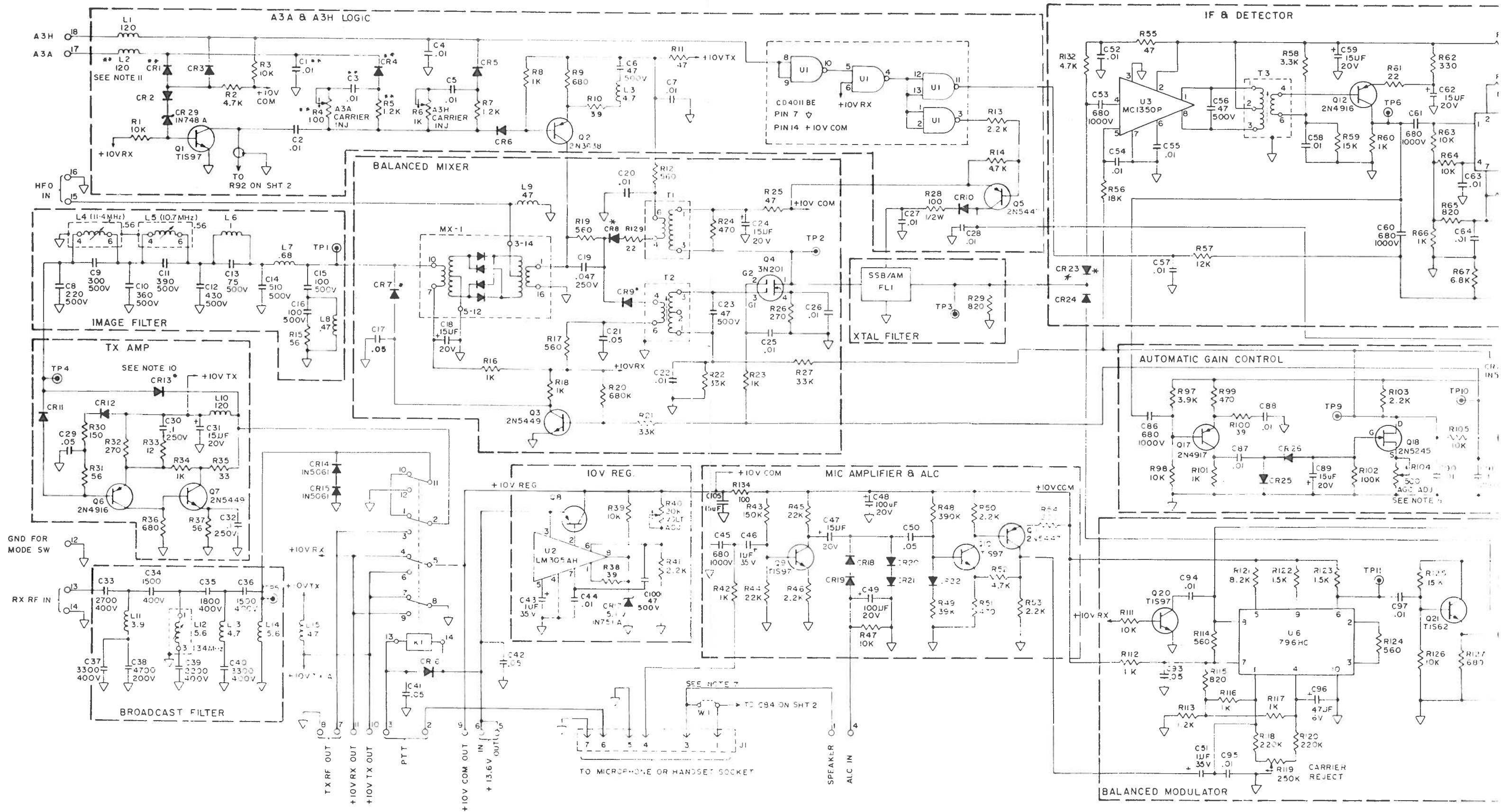
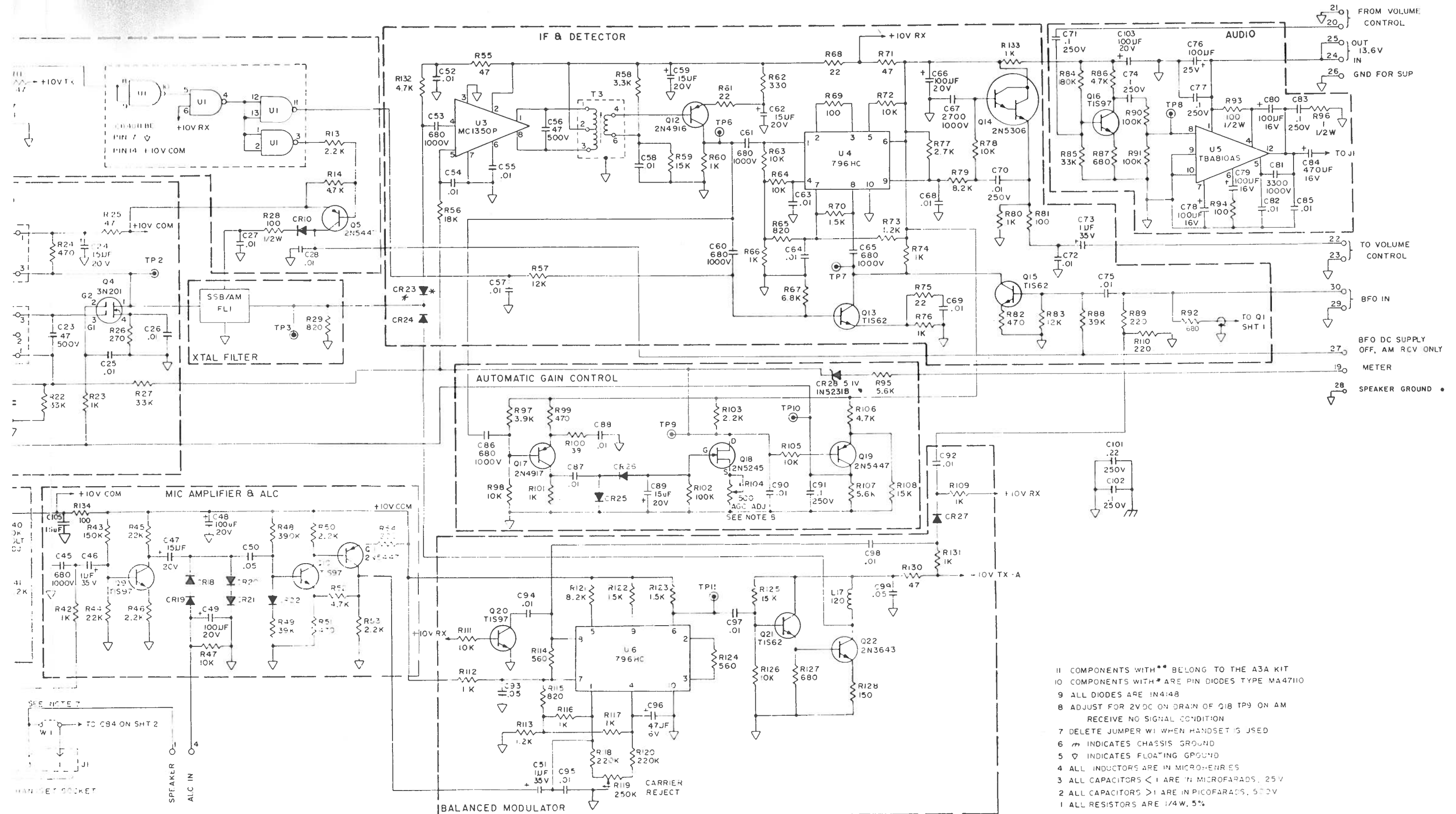

FIGURE 7-5 TRANSMITTER/RECEIVER SCHEMATIC DIAGRAM

Unfold for:

FIGURE 7-4



- 11 COMPONENTS WITH ** BELONG TO THE A3A KIT
- 10 COMPONENTS WITH * ARE PIN DIODES TYPE MA47110
- 9 ALL DIODES ARE 1N4148
- 8 ADJUST FOR 2V DC ON DRAIN OF Q18 TP9 ON AM RECEIVE NO SIGNAL CONDITION
- 7 DELETE JUMPER W1 WHEN HANDSET IS USED
- 6 ∞ INDICATES CHASSIS GROUND
- 5 ∇ INDICATES FLOATING GROUND
- 4 ALL INDUCTORS ARE IN MICROHENRES
- 3 ALL CAPACITORS < 1 ARE IN MICROFARADS, 25V
- 2 ALL CAPACITORS > 1 ARE IN PICOFARADS, 500V
- 1 ALL RESISTORS ARE 1/4W, 5%

NOTES (UNLESS OTHERWISE SPECIFIED)