

# The Marconi CR Series of Receivers

by G. L. Grisdale PhD G5GZ

The life of Guglielmo Marconi (1874 to 1937) and the history of his Companies are both well documented in books available in many public libraries (Refs. 1 to 5). Born of an Irish mother and an Italian landowner, he had a very mixed education, partly with private tutors and schools including a two-year stay as a small child at Bedford, and partly by attendance unrelated to any organised course at scientific lectures in his native country.

As a result of his reading of papers about the early scientific investigations into wave propagation, he experimented between 1894 and 1896 with wireless communication using spark coil generation of oscillation, the only source of radio frequency oscillation at that time and more than a decade afterwards. At first the communication was across an attic room at his parents' country home near Bologna, but then the apparatus was taken out of doors and signals were ultimately received over a distance one and a half miles.

Unlike his scientific predecessors Hertz and Lodge, who used short dipoles indoors, Marconi obtained greater ranges with similar equipment joined to elevated wire aerials. So long as the spark coil could maintain the high voltage with the larger capacitance, the energy of each impulse was greater and the radiated power more.

On the receive end also the larger aerial would collect more power in a given field strength; the elevated aerial was the first major discovery.

Having received no encouragement for the wireless communication system from the Italian authorities, Marconi came with his enterprising mother to London where they had good contacts with business people, notably through his mother's family Jameson Irish whiskey connections. The chief engineer of the Post Office gave facilities for short-range demonstrations in London, and further demonstrations of the equipment brought from Italy in the West Country produced interest from the Services, particularly the Navy because of the possibility to improve communication to ships. Finally in March 1899 the Channel was bridged between Wimereux and South Foreland.

George Grisdale was born in 1914 and had the call G5GZ in 1931, the experimental station licence being given up after a few years. From 1937 to 1980 he worked for Marconi's, for 13 years on receiver design and after that on communication projects in the Research Laboratories at Great Baddow. He now lives in Langport, Somerset, and the old callsign was reissued in 1989.

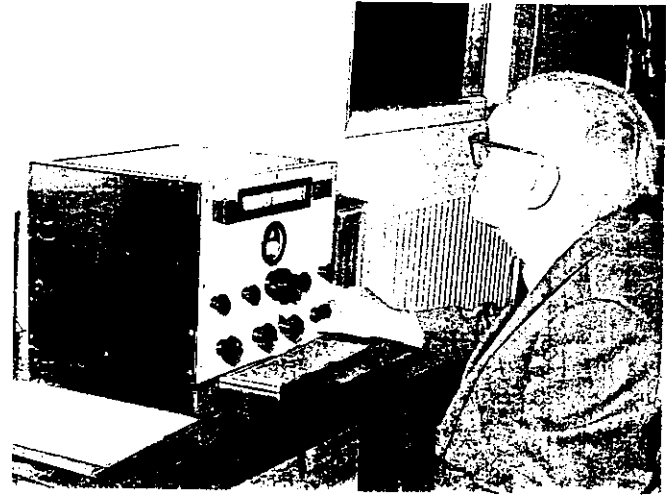

The author, pictured in 1986. He was a member of the team responsible for the design of the CR100 and of the CR150

## Origins of the Marconi Company

On the business side, the Wireless Telegraph and Signal Company was formed in 1897, changing its name three years later to Marconi's Wireless Telegraph Company (MWTCo); this survived until 1963 when it became the shorter Marconi Company. Also in 1900 a subsidiary company, the Marconi International Marine Communication Company (MIMCo) was formed to deal with the important maritime matters; apparatus and radio officers were supplied to ships as a service and the company continued as an operating organisation until recently.

Until about 1912 the spark gap remained the only way to generate radio frequency oscillations, necessarily of a pulse nature. Various receiving detectors were used, notably the filing coherer, the crystal rectifier, Fleming's diode valve and the reliable magnetic detector. Some devices worked paper tape recorders through sensitive relays but most gave audible sounds in telephones. The main endeavour at the time was to improve communication to ships and to develop the very high-power transmitters for long-distance communication between land stations. In the early 1920s, improvement in vacuum pumps and the production of larger transmitting valves led to the establishment of broadcasting and the discovery of long-distance propagation of high frequency waves, leading to the inter-continental beam services. At the same time there was rapid development of long distance amateur contacts using comparatively low-power transmitters.

## Receiver Design

During the 1920s and '30s several separate development groups in the Marconi Company designed receivers for various purposes. Some of these receivers had their input circuits modified for use with direction-finding aerial systems using loops, rotating spaced frames and four-poster Adecock arrangements for land stations, which were an important navigation and security function then as in those days. Marine equipment was designed by a group in MWTCo and was installed and operated on merchant ships by MIMCo.

staff. Portable receivers had RP type numbers; aeronautical had the AD series, one of which led to the well-known T.1154/R.1155 bomber equipment (Ref. 7) of which 80 000 were made in the Second World War. Large rack receivers for the beam international service were designed at the Broomfield site in Chelmsford, with RC type numbers.

Lastly, the general purpose receivers in the '20s and '30s were the RG series, designed by the Receiver Group of the Development Department at Writtle. The group were housed in the huts which had been the location for the Tuesday evening half-hour evening 'concert' transmissions in 1922 from 2MT which preceded the formation of the BBC. In the late 1930s the group consisted of about eight engineers led by R. B. Armstrong, with the invaluable assistance of Dr Erich Zepler who had been chief of receiver design of Telefunken before Mr Hitler compelled him to emigrate, and who later became the first Professor of Electronics at Southampton.

As in the domestic receivers, the superheterodyne had replaced the earlier straight receivers and the later RG receivers used ganged capacitor tuning and large rotating coil-drums instead of plug-in coils (Ref. 6). Much work was done on the contact strips of the coil drums, including rhodium plating to give a non-tarnishing contact. The other constant search of those days was for a rubber or synthetic covering for connecting wire which would neither harden nor emit gases which would corrode the contacts. In 1938 the main established designs were the RG34 for the HF bands and the RG35 long-wave receiver. The RG42 was being developed to replace the RG34.

In the Spring of 1939 the receiver group moved to the newly-built Research Laboratories at Great Baddow on the east side of Chelmsford. They remained at Baddow until 1950 when they began moves to various sites in the Chelmsford area.

## The CR100 is Born

In 1939 it was decided to embark on a new receiver design, partly to offer the Royal Navy a British made receiver as an alternative to the excellent HRO which was widely used. The intention was to use components purchased from outside suppliers who were already supplying part of the broadcast receiver industry; details of the circuit design, inductor windings and filters were fully specified by the receiver group. So as to avoid any disruption by enemy bombing there were to be several suppliers for each component, and several locations for assembling and testing the complete receivers.

The experimental model design was started in July 1939, two months before the outbreak of World War II. The circuit followed normal communications receiver practice at that time with two tuned signal-frequency amplifiers, hexode mixer with separate oscillator, three intermediate-frequency amplifiers at 465kHz, double diode-triode signal rectifier and AGC rectifier and audio amplifier. A two watt audio output was provided, probably unnecessarily high for most purposes, with lower level line and telephone output connections.

The experimental model was taken to Portsmouth for assessment in the Spring of 1940 and the first 500 models of the CR100 were assembled in a former chapel in Huddersfield by the Westminster Chassis Company, the first batch of twelve being sent to Baddow for adjustment and test in the

Spring of 1941. The subsequent main assembly plant was at Broomfield, Chelmsford, a very old Marconi location, a production of over 100 receivers per week being achieved in the war years. In all eight editions were produced for the three Services, including the blue panelled CR100/7 which became the Navy B28. (see RB No. 12 for a colour photo - Ed.)

## Technical Features

The input coil coupling gives about 75 ohms impedance over the bands; there is a second input, capacitance coupled to the first tuned circuit for random wire antennas. A panel-controlled trimmer peaks the first tuned circuit. A receiver in good condition, with the antenna disconnected, should give an increase of noise output on at least the five lowest frequency bands, when the trimmer is tuned to give resonance (Ref. 6). The signal frequency gain increases at the high-frequency end of each band because simple capacitance tuning is used on all three stages.

The four-section tuning condenser rotated by a spring-loaded gear train incorporates a logging scale and a cord-driven frequency scale using a drum coupled to the wave-change switch. The drum was printed with the six scale lines and numbers, but the actual frequency calibration lines were added manually with the aid of a specially made harmonic crystal calibrator. The drive cords can be replaced, but it is not a welcome job for unsteady hands.

The first step in adjusting the signal frequency circuits is to set the first oscillator to the scale frequency indications, using an accurately calibrated signal generator to the antenna connection; inductances L19 to L24 are adjusted at the low-frequency end of each band; at the high-frequency ends there are adjustable capacitance trimmers C33 to C35 on bands 1 to 3, but on the higher frequency bands 4 to 6 fixed capacitors have been soldered on top of the coils on test; this is to improve frequency stability. When the oscillator ranges are correct the three signal frequency components are peaked in the same way, inductances at the LF ends and capacitance trimmers in units 2 and 3 at the HF ends.

Four intermediate-frequency bandwidths are selected by a wafer switch, the transformer inductors being adjusted on the 3000Hz bandwidth. The single-crystal filter is peaked to give its widest bandwidth on the 1200Hz position, the narrower 300Hz bandwidth being obtained by switching the 7pF capacitor C43 from the input to the output filter circuits. The 100Hz width on CW only is provided by a 1000Hz audio bandpass filter; the BFO must be adjusted to give a 1000Hz note with a signal giving maximum output from the narrow band crystal filter.

The AGC diode is fed from the primary of the final IF transformer, the BFO being injected at the secondary; this is to avoid operation of the AGC on CW when the BFO is switched on. If this occurs the AGC should not be used on CW.

The CR100/2 receivers only have a side-tone facility when used with a transmitter provided with an operating switch which opens when transmitting. This decreases the receiver gain by applying increased cathode voltage from R57 mounted inside the receiver.

A plug-board inside the receiver enables the receiver to operate either from 50Hz mains or from high- and low-tension battery supplies, connected through the five-pin power plug

# Specifications

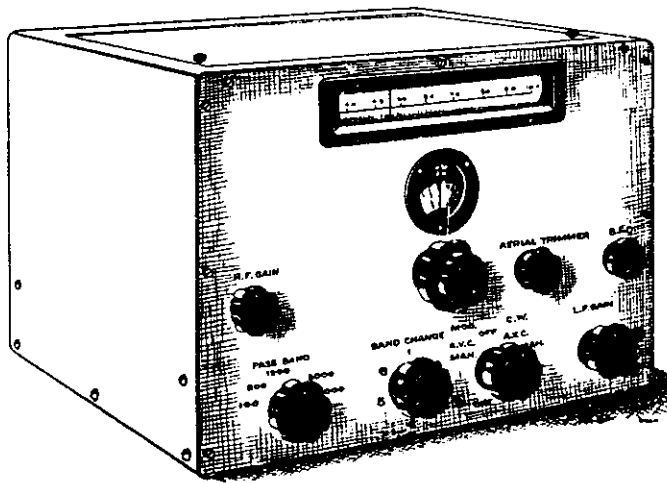

## CR100/2 (Handbook T1868/1)

**FREQUENCY RANGE:**  
 60 – 420kHz in two bands  
 500kHz – 30MHz in four bands

**DC SUPPLIES:** 6V 4A, 250V 100mA  
 (Reduced to 160V 60mA if desired)

**MAINS SUPPLY:** 200–250V 50Hz 85W

**INPUTS:** 100Ω feeder, balanced or unbalanced, or high impedance antenna

**SENSITIVITY:** 20dB s/n ratio on CW in 3kHz bandwidth  
 60kHz – 11MHz: 1 – 2μV  
 11 – 30MHz: 1.5 – 4μV

**OUTPUTS:** Speaker: 3Ω (1kΩ CR100/4 to /8) 2W max.  
 Line: 600Ω, about 2mW.  
 Phones: high or low Z in various editions

**EDITIONS:** CR100 to CR100/8 (inc. Navy B.28)

**DIMENSIONS:** 16 x 16.5 x 12.5in. Weight 82lb

**VALVES:**

Position	Preferred	Possible alternatives
V1, 2, 4 to 7, 10	KTW62 (VR100)	KTW61 (NR64), 6K7G, 6J7G
V3	X66 (VR99)	X65 (NR82), 6K8G
V8	DH63 (NR68)	6Q7G
V9	KT63 (NR85, ARP17)	6F6G, 6V6G
V11	U50 (NU20)	5Y3G, 5Z4G (U52)



## CR150/3 (Handbook T2148/1)

**FREQUENCY RANGE:**  
 2 – 60MHz in five bands

**DC SUPPLIES:** 300V 65mA  
 6.3V 3.7A

**MAINS SUPPLY:** 90W (separate power unit)

**INPUTS:** 75 – 100Ω balanced or unbalanced

**SENSITIVITY:** 20dB s/n ratio on CW in 8kHz bandwidth  
 2 – 16MHz: 1 – 2μV  
 16 – 32MHz: 2 – 4μV  
 32 – 60MHz: 7 – 14μV

**OUTPUTS:** 1mW to HR or LR headphones.  
 200mW to 600Ω line or 3Ω loudspeaker

**EDITIONS:** CR150 to CR150/6

**DIMENSIONS (CR150/3):**  
 20.5 x 17 x 14in. Weight 28kg (receiver)

**VALVES:**

Position	Preferred	Possible alternatives
V1 to V4	EF50 (VR91)	CV1091
V5	X66 (NR82)	CV1099
V6, 7, 9	6K7G (NR81)	KTW63, NR86
V8, 10	DH63 (NR68)	6Q7G (CV587)
V11	L63	CV1067, 6J5G (CV1932)
V12	STV280/40	VS68, CV1068
Power unit	U52 or metal rectifier	

All photographs and illustrations courtesy GEC-Marconi Limited, unless otherwise acknowledged

## Old CR100 Receivers

The last CR100 receiver was probably made in 1946 after some 20 000 had been manufactured. Although many remain in working order to this day, some attention may be required to restore full performance.

Electrolytic capacitors tend to lose capacitance over long periods: the power supply should be checked for output and hum, the 8+8+8μF condenser being replaced if necessary. Rather more vulnerable are the cathode by-pass condensers CR7 and CR8 which can be replaced by modern types slung

in the wiring; this may restore low audio gain.

It may be found that the receiver gain increases when switching from manual to AGC, contrary to what might be expected. The tagboard strips on which resistors are mounted were made of Bakelised linen sheet which can absorb moisture and become leaky enough to produce positive voltage on the AGC line from the HT decoupling resistors.

In the intermediate-frequency transformers of earlier receivers the dust-iron inductance adjustment cores were mounted on 6BA brass studs with flats and locknuts which must be slackened before turning. Some later sets had dust

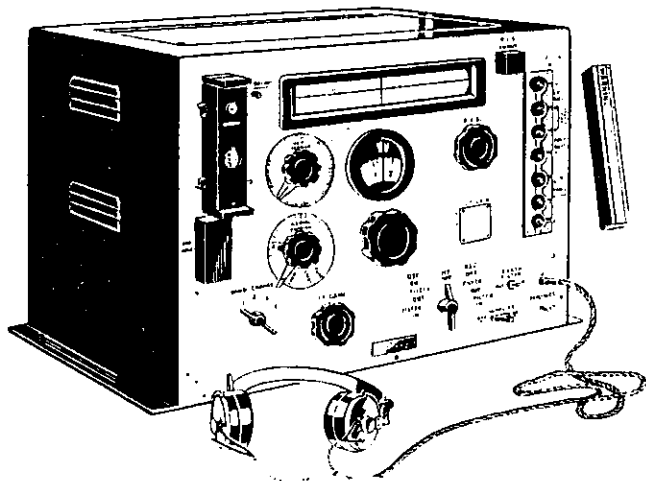

### CR200 (Navy B29)

**FREQUENCY RANGE:**

15 – 550kHz in four bands

**DC SUPPLIES:** Batteries 200V 22mA max, 6V 2.1A

**MAINS SUPPLY:** 100/110 or 200/250V AC 33W

**INPUTS:** Dipole or unipole via 80Ω feeder.  
High or low-impedance loop aerial  
(15 – 90kHz only)

**SENSITIVITY:** See Note 1

**OUTPUTS:** Jacks for Pattern W.621 head telephones.  
5000Ω line for Auto High-speed reception  
using DC Amplifier M31

**DIMENSIONS:** 19 x 13.5 x 16in. Weight 82lb

**VALVES:**

Position	Preferred	American type
V1, 2	VR100 (KTW62)	6K7G
V3	VR99 (X66)	6K8G
V4	NR68 (DH63)	6Q7G
V5	6J5G (L63)	6J5G
Power unit	VU71A	5U4G

Note 1: The handbook AP S.S.104 gives no sensitivity specifications. However, a Test Certificate for a typical B29 receiver shows a 10dB S/N ratio was achieved across the frequency range with signals of 0.1 – 0.15μV to the 80Ω input

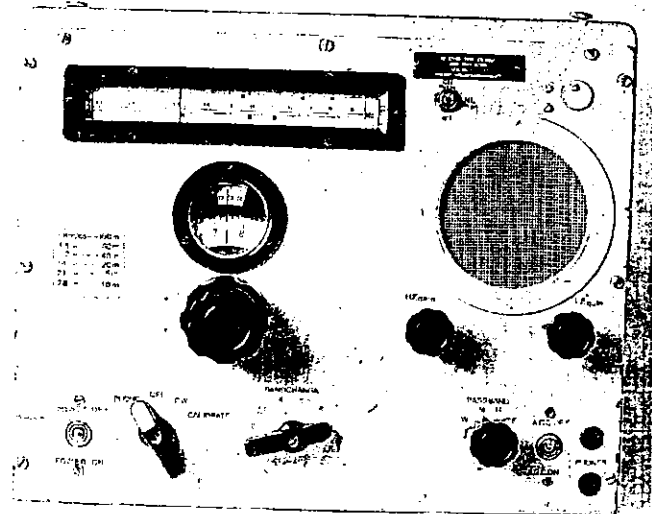

### CR300 (Handbook T1864/2)

**FREQUENCY RANGE:**

15kHz – 25MHz in eight bands

**SUPPLIES:** 250V 60mA, 24V 0.95A.

(Using the Type 889 Supply Unit, the receiver can be operated from 230V 50Hz AC, or 24V, 110V or 220V DC)

**INPUTS:** Single wire aerial not exceeding 700pF  
(including feeder).

100Ω feeder at higher frequencies

**SENSITIVITY:** 20dB s/n ratio on CW

85kHz – 25MHz: 2 – 5μV

15kHz – 85kHz: 35 – 70μV

**OUTPUTS:** 2W to internal (or ext.) 3.5Ω loudspeaker.  
10mW to 60Ω headphones

**EDITIONS:** CR300/1 with 500kHz crystal calibrator.  
CR300/2 with 690kHz crystal calibrator

**DIMENSIONS:** 18.75 x 15.5 x 13.625in. Weight 55lb

**VALVES:**

Position	Preferred
V1, 3, 4, 6, 8	KTW61
V2	X66
V5	DH63
V7	6V6G
Power Unit	6X5G

CR300/1 photographed at the Chalk Hills Museum by Geoff Arnold

cores with screwdriver slots, inserted in the Bakelite coil formers with a white paste which hardens with the years and makes it difficult to turn the cores without breaking the slot. A drop of solvent on the core may help, with patience.

Removing any of the signal-frequency coil units is not a task to be undertaken lightly. Having removed the case from the chassis the wavechange switch spindle should be released from the coupling to the switch click drive and withdrawn. Then there are three to five soldered wires to be released, including those through the chassis to the tuning condenser, after which the coil unit can be removed.

Various insulation was used on the connecting wires during the war years and some of the rubber based types may harden and crack in old receivers. A particular cause of short circuits in the detector region is wires trapped under the edges of the rectangular screening box covering the bases of V8 and V10. The receiver should work without this box which was fitted to avoid feedback of BFO harmonics to the signal stages.

A number of technical handbooks (no longer available from Marconi's) were issued including T 1868/1.

During the war years three further CR receivers were developed, namely, CR150, CR200 (Navy B29) and CR300.

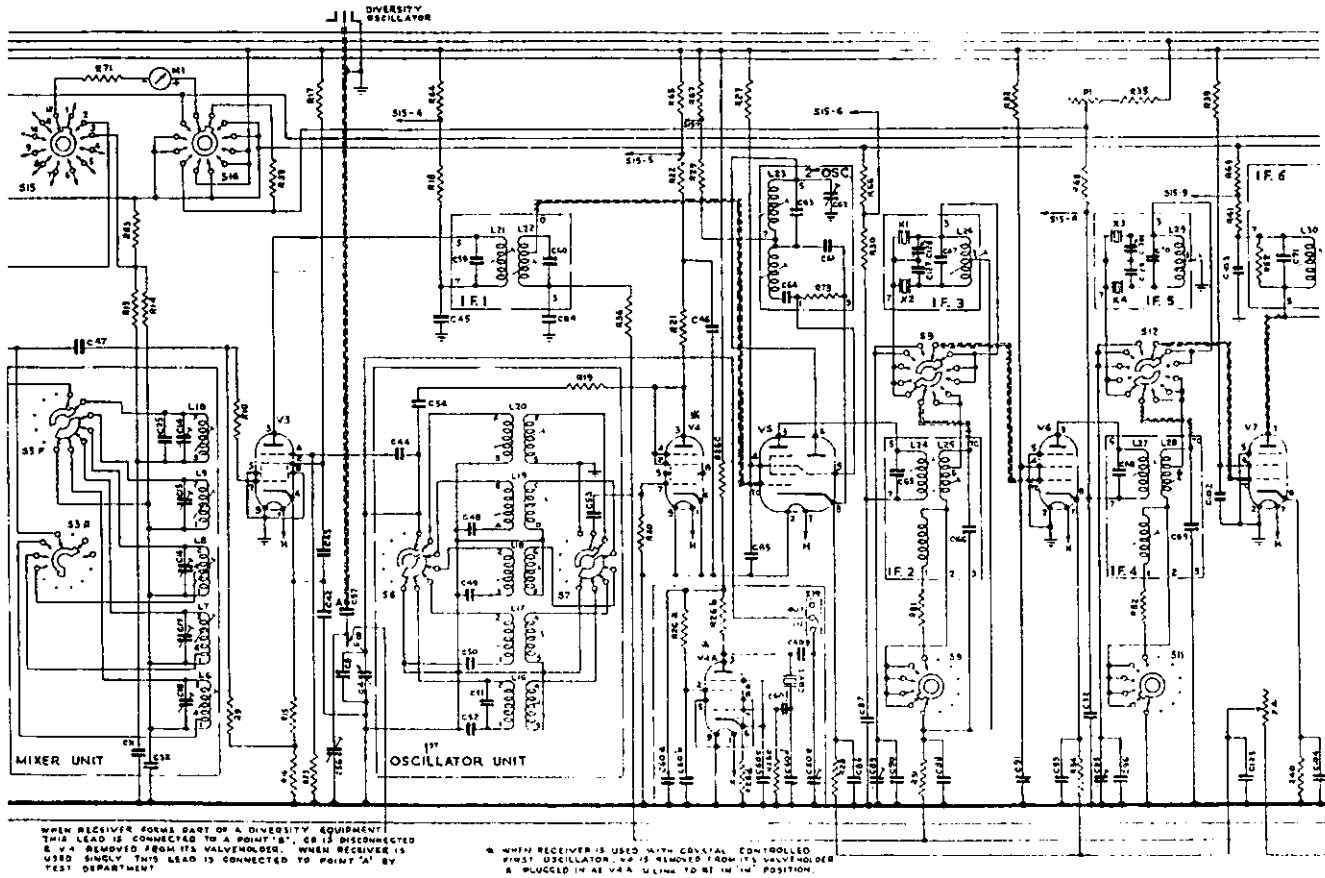

Part of the circuit diagram of the CR150/3 receiver, covering the Mixer, 1st Oscillator, 2nd Oscillator and IF Stages. It shows the arrangements for the external 1st Oscillator feed when the receiver is operating in a diversity installation, and also for crystal control of the 1st Oscillator as an alternative to continuously variable tuning

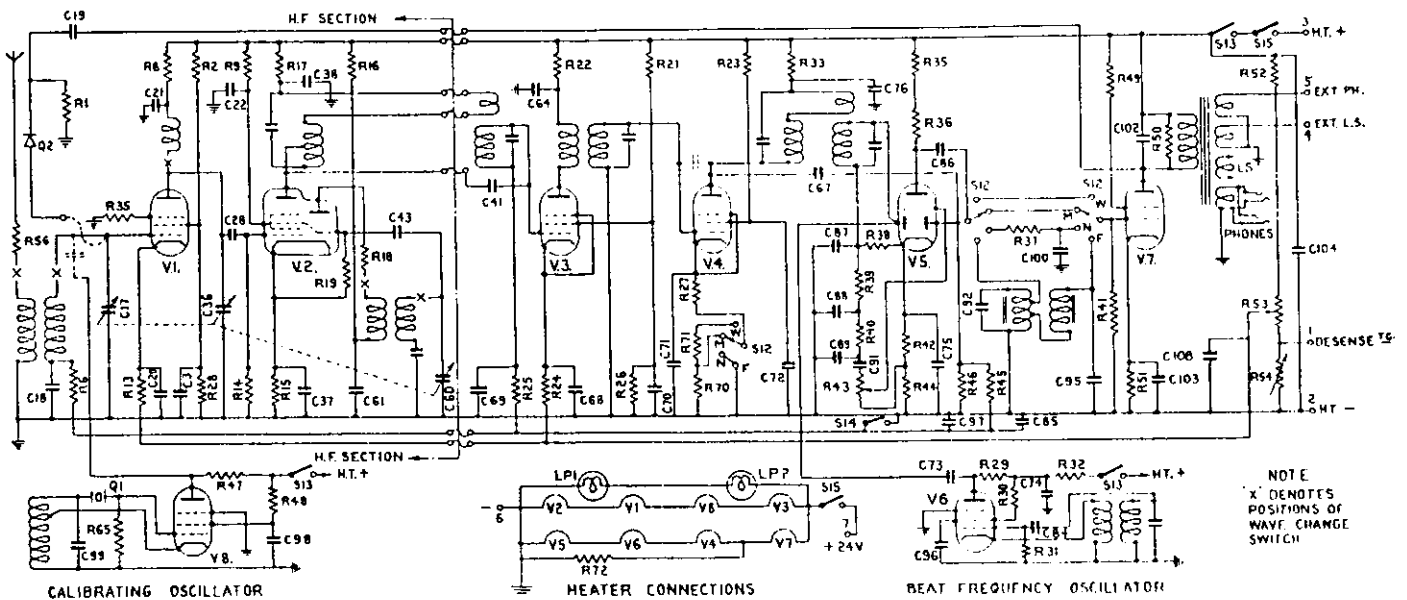

Simplified circuit diagram of the CR300 receiver

Editor's Note: Diode Q2 is a carborundum/steel detector, which could be brought into circuit by transferring the grid top-cap connector from RF Stage V1 to a special point provided on the crystal assembly. Until the early 1950s, it was a requirement of the Merchant Shipping (Wireless Telegraphy) Rules that the radio installation on board a British-registered ship should be capable of 'maintaining reception by means of a rectifier of the crystal type'. Q2 provides this facility.

Subsequent editions of the Rules called for a separate emergency or reserve receiver.

A facility for reducing the RF/IF gain of the receiver when an associated transmitter is 'key-down' is provided, similar to that on the CR100/2. Whereas on that receiver it is called 'Side-tone', on the CR300 it is called 'Desensitising'

## The CR150

The CR150 was a short wave receiver with improved sensitivity, crystal filter selectivity and frequency stability.

The CR150 has six editions; up to the CR150/4 the two signal frequency amplifiers, mixer and first oscillator use EF50 high slope valves to give the maximum sensitivity (Ref. 6).

The four-gang tuning capacitor has less than half the capacitance of that of the CR100 and has extra wide spacing in the front oscillator section; a bi-metal trimmer is mounted above the tuning condenser to compensate for the frequency drift caused by temperature change in the cabinet; the audio output was also dropped to 200mW.

The original CR150 covered the range 2 to 60MHz, with a first intermediate frequency of 1600kHz; for direction finding application the IF was 1200kHz so that the frequency 1500kHz could be covered. The performance on the top range to 60MHz is not good; it was included to satisfy the needs of one user.

The CR150 has a final intermediate frequency of 465kHz: two crystal filters are included each using two resonators to give a better band-pass response than the single crystal circuits previously used. Although not designed for single sideband reception, the 3kHz bandwidth gives satisfactory results with such signals, so long as the BFO is adjusted to give a carrier on the upper or lower edge of the filter response, according to which sideband is being used by the transmitter. A 500kHz crystal oscillator gives harmonics for calibration purposes.

After 1950 the CR150/6 was developed using 6AM6 (EF91) and other 7-pin button-based valves in the following stages instead of the EF50 and octals. It also had provision for six plug-in crystals for reception on spot frequencies.

## The CR200

The CR200 (Navy B29) is a 5-valve TRF receiver (2-v-2) covering 15 to 550kHz in four bands. Two audio stages include a narrow bandwidth filter tuned to 1kHz for CW reception. Aerial arrangements include two 'loop' inputs, intended for use in submarine installations where a single-turn loop or frame aerial is fitted for submerged reception, on the lower two frequency bands (15 to 90kHz).

For operation with such very insensitive aerials, the CR200 was given very good sensitivity; however, with any normal aerial more than a few feet long, the atmospheric (route) noise would exceed the internal receiver noise. For long-wave DX enthusiasts the good receiver sensitivity would not matter much.

## The CR300

The CR300 was designed in the early war years by Mr G. J. McDonald, to whom we are grateful that he raided his memory for details. It was designed for maritime application with the wide frequency range 15kHz to 25MHz; it is identified by the forward facing loudspeaker in the cabinet, and some power supplies with a vibrator interrupter for DC power inputs.

Two editions of the CR300 were made; the CR300/1 was widely used by the Royal Navy from 1943 with the TGY2

transmitter on frigates and motor gun boats. It has a 500kHz crystal calibrator and a desensitising facility to use with suitable transmitters, and also the RIS (Radar Interference Suppression) circuit for reducing possible radar interference.

The CR300/2 was used on merchant ships until replaced by the Marconi 'Mercury' (T.1017) and 'Electra' (T.1018) duo, covering LF/MF and MF/HF respectively, and later the Marconi 'Atalanta' (T.2207).

The wide frequency range of the CR300 was obtained by using an aperiodic signal amplifier between 15 and 85kHz, the lower sensitivity being adequate with the high noise levels at these frequencies. Intermediate frequencies of 98 and 570kHz were used on various bands to give continuous coverage over 15kHz to 25MHz, and the CR300/2 has a 690kHz calibrator to give harmonics in the maritime high-frequency bands.

## Diversity Equipment

Because ionospheric transmission causes fading of signals, the professional services used various forms of diversity reception to improve the accuracy of messages received. Four methods were possible: sending messages twice (time diversity), sending simultaneously on two frequencies, receiving the same transmission on antennas with different polarisation, and receiving on spaced antennas.

The last method was the most used. Evidently reception simultaneously through two channels requires several receivers.

Some CR receivers were modified to fit them to double or triple diversity equipments such as the CRD150. It was necessary to operate such combinations with common frequency changing oscillators and combining circuits, so that some receivers such as the CR150/4 may be found with internal oscillators missing.

## Acknowledgements

Thanks are given to the Marconi Company and particularly to Mr Roy Rodwell its Historian for permission to use copyright photographic and handbook material. Also to Mr G. J. McDonald, formerly Technical Director of MIMC for information about his CR300.

## References

1. Degna Marconi, *My Father Marconi*, Muller 1972, revised 1982.
2. W. P. Jolly, *Marconi*, Constable, 1972.
3. Keith Geddes, *Guglielmo Marconi*, Science Museum Booklet, HMSO 1974.
4. R. N. Vyvyan, *Wireless Over 30 Years*, Routledge, 1933. Reprinted as *Marconi and Wireless*, E.P. Publishing, 1974.
5. W. J. Baker, *History of the Marconi Company*, Methuen, 1970.
6. G. L. Grisdale and R. B. Armstrong, 'Tendencies in the Design of the Communication Type of Receiver', *JIEE*, Vol.93, Pt.III, No.25, Sept. 46.
7. Chas E. Miller, 'Valved Communications Receivers -- the R.1155', *Practical Wireless*, March & May 1985
8. Chas E. Miller, 'Valved Communications Receivers the CR100/B28', *Practical Wireless*, June 1986. **RB**

ALL SWITCHES SHOWN FULLY  
COUNTER - CLOCKWISE.  
CONTACTS AS VIEWED FROM FRONT.  
FRONT ROTOR MARKED F.  
REAR ROTOR MARKED R.  
⊕ INDICATES SCREENED LEAD  
WITH SCREENING EARTHED.

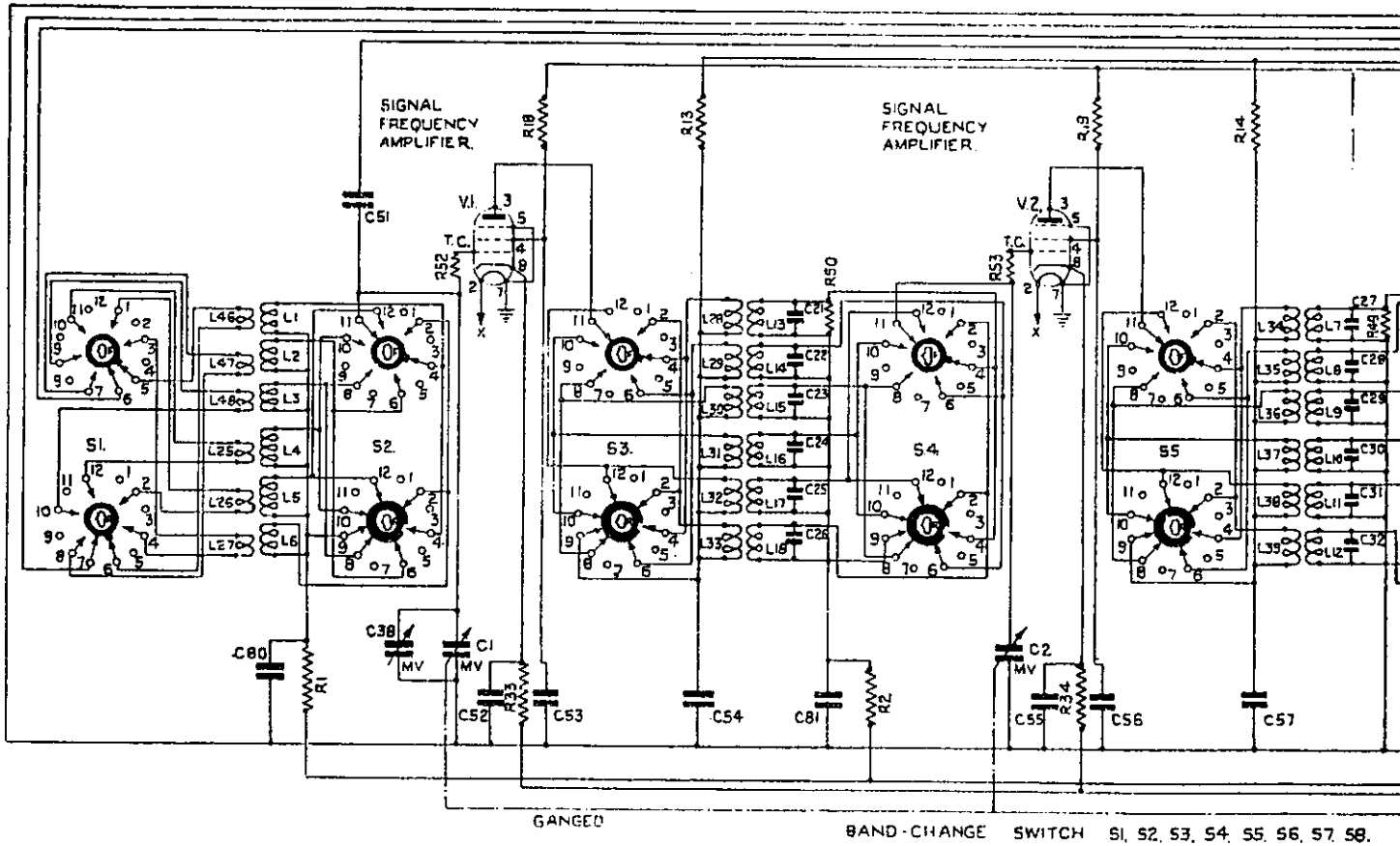
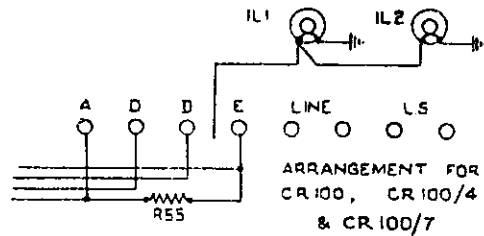

Complete circuit diagram of the CR100

**CONDENSERS**

C1-C4	4-gang 437.5pF
C5-C12	350pF 2%
C13	20pF
C14	25pF
C21-C35	5-50pF
C36, C37	SOT
C38	25pF
C39	SOT
C40	10pF
C41	2000pF
C42	420pF
C43	7pF
C44	55pF
C45	150pF
C46	460pF
C47	1190pF
C48	3400pF
C49	10 000pF
C51	10pF
C52-C77	0.1μF
C78, C79	1μF

C80, C81	0.1μF
C82	0.01μF
C83	500pF
C84	0.01μF
C85	100pF
C86	30pF
C87, C88	25μF 25V
C89	8-8-8μF 400V
C91	0.1μF
C92-C94	100pF
C95, C97	500pF
C96	2000pF 500V
C103, C104	Mica trimmer
C105, C106	3100pF
C110, C111	0.01μF

**RESISTANCES**

R1, R2	47kΩ
R3	22kΩ
R4, R5	47kΩ
R6	47Ω
R7	22kΩ

R8	47kΩ
R9	20kΩ
R10	220kΩ
R11	470kΩ (CR100, CR100/2) 47kΩ on other models
R12	10kΩ
R13-R17	2.2kΩ
R18, R19	4.7kΩ
R20	39kΩ
R21-R23	4.7kΩ
R24	22kΩ
R25, R26	100kΩ
R27	1MΩ
R28	1.2kΩ
R29	10kΩ
R30	470Ω
R31	470kΩ
R32	1MΩ
R33-R38	390Ω
R39, R40	10kΩ 5W
R41	2kΩ pot
R42	500kΩ pot

BEAT FREQUENCY OSCILLATOR.

HT R

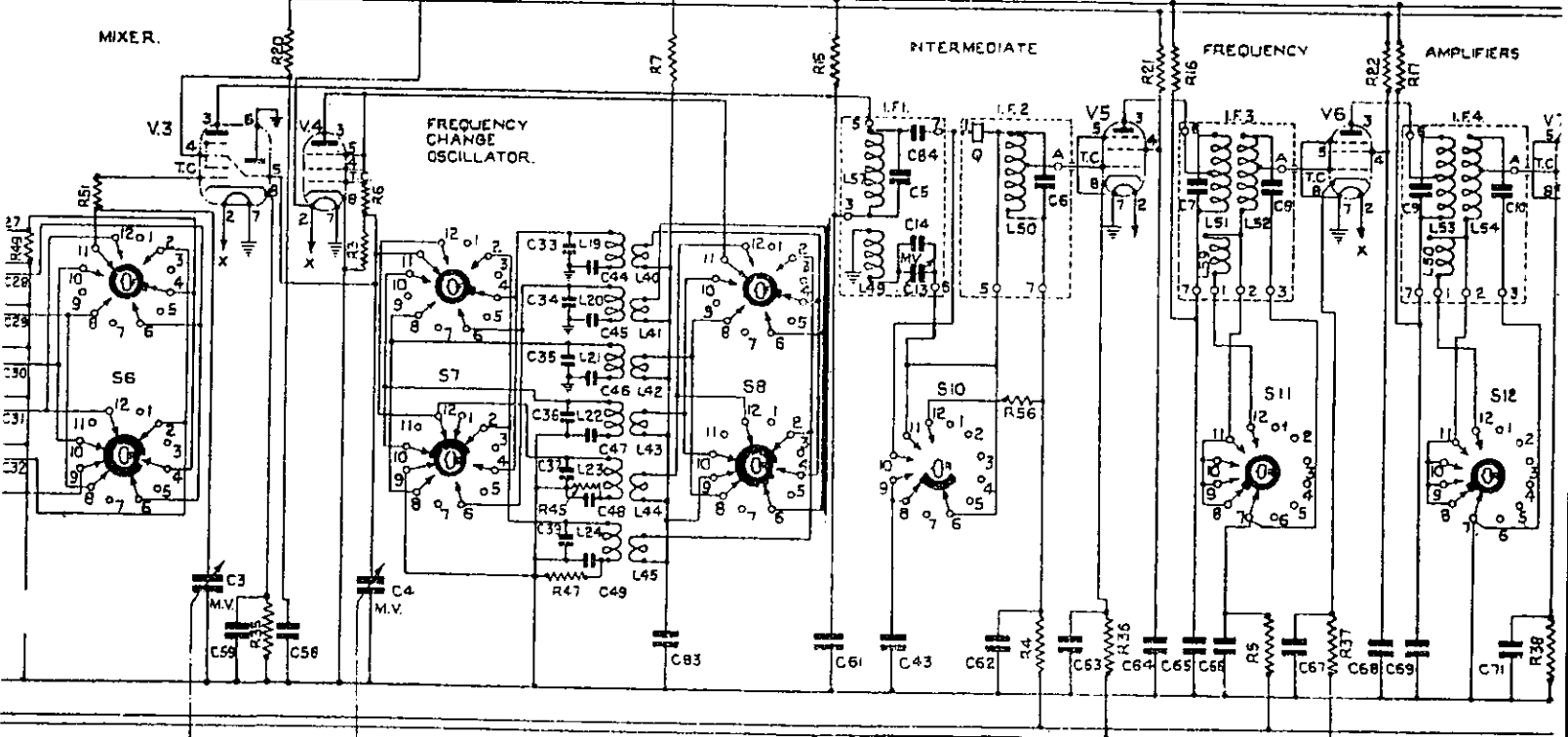
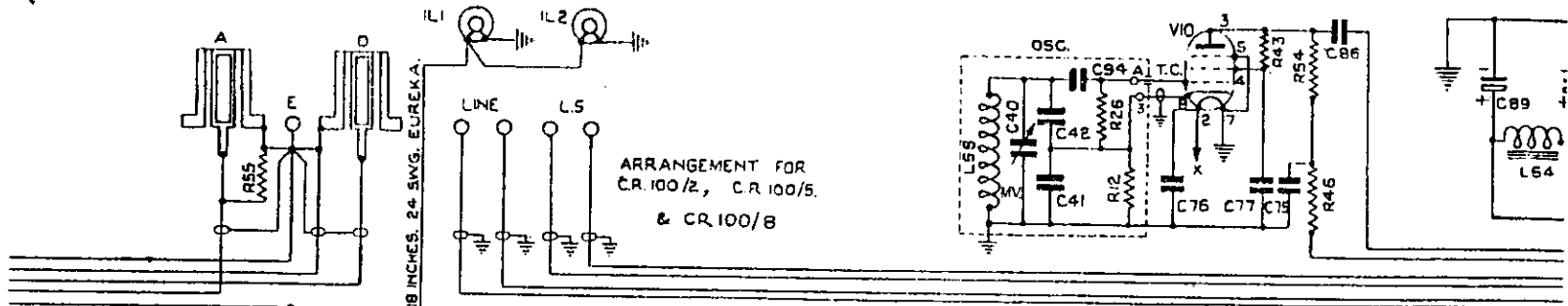

3. GANGED  
PASS-BAND SWITCH S10, S11, S12, S15

- R43 100kΩ
- R44 2.2kΩ
- R45, R46 22kΩ
- R47 3.3kΩ
- R48 560Ω
- R49, R50 220kΩ
- R51-R53 10Ω
- R54 100kΩ
- R55 2.2MΩ
- R56 100kΩ
- R57 2kΩ pot (CR100/2 only)

- INDUCTANCES**
- L61 1μH
  - L62, L63 Iron-cored
  - L64, L65 8H 120mA

- VALVES** (see specification table)
- FUSES:** F1 2A; F2 500mA A/S
- LAMPS:** IL1, IL2 6.5V 0.3A MES

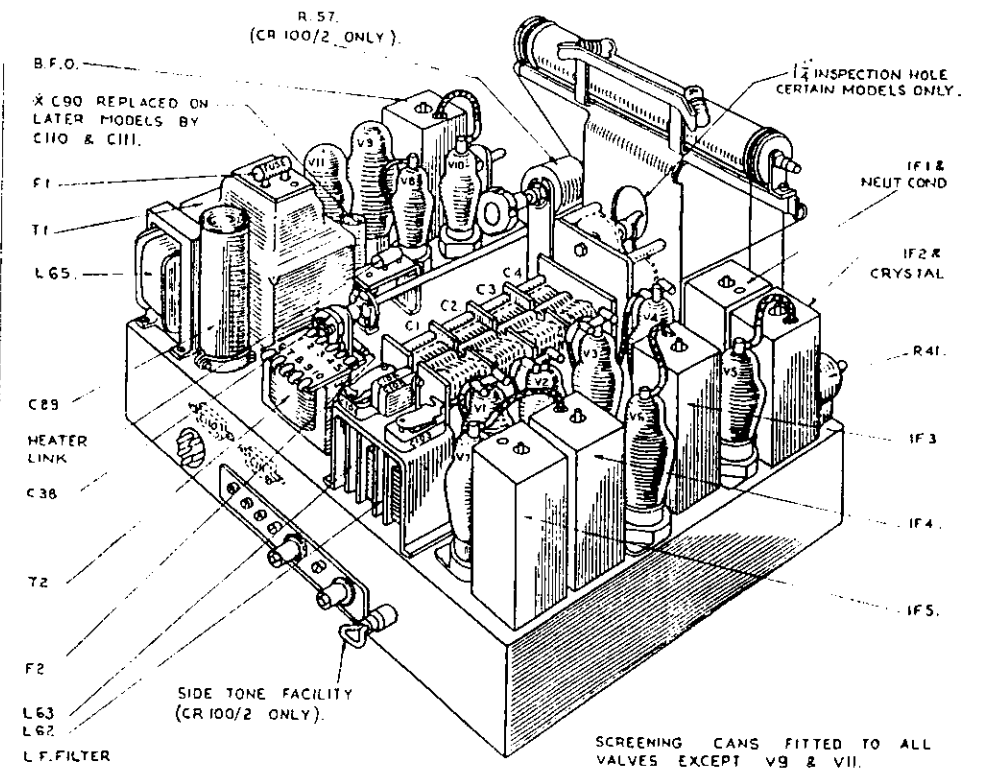



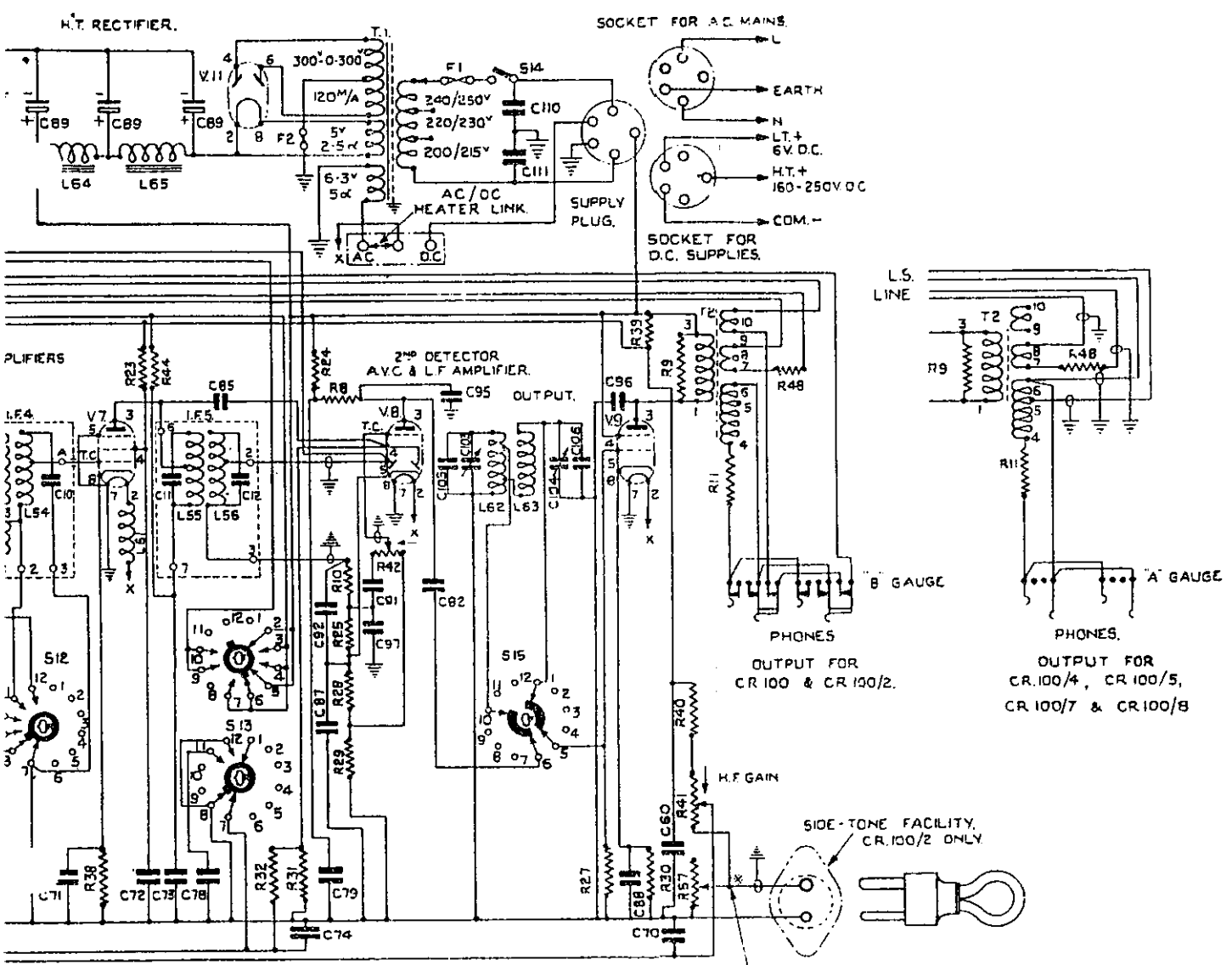

OPERATIONAL SWITCH S13.

\* THIS POINT EARTHED ON ALL MODELS EXCEPT CR100/2.

WZ1943

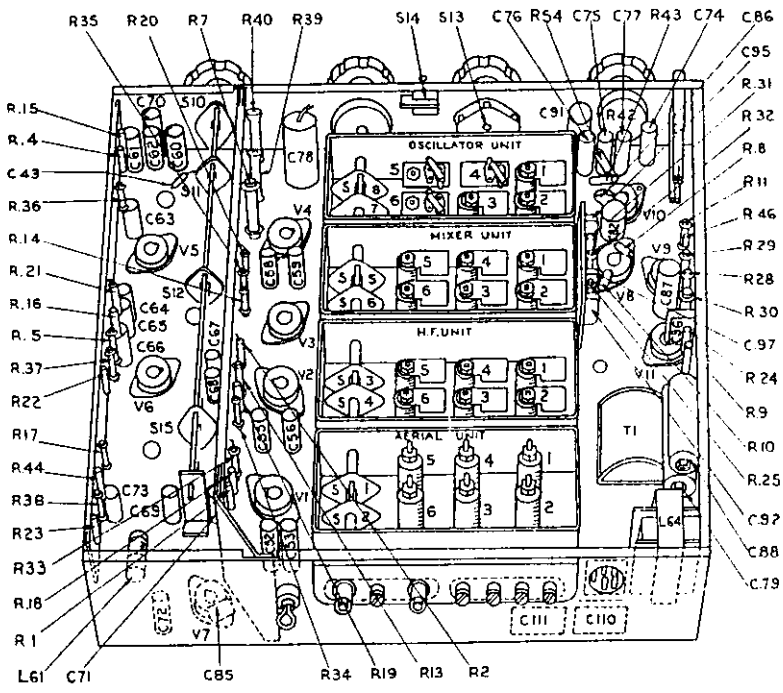

Top and underside layouts of the CR100

## CR100 Version Differences

### Aerial input facilities:

- CR100, /4, /7:
  - Balanced or unbalanced low-Z (100Ω).
  - Unbalanced high-Z.
- CR100/2, /5, /8, /8(Mod):
  - Unbalanced low-Z (100Ω).
  - Unbalanced high-Z.

### Loudspeaker load impedance:

- CR100, /2, /8(Mod):
  - 3Ω.
- CR100/4, /5, /7, /8:
  - 1000Ω.

### Noise limiter fitted:

- CR100/7, /8, /8(Mod) only – double-diode VR54 (EB34) and on/off switch mounted on small board, adjacent to Heater Link panel.

### Side-tone facility:

- CR100/2 only.